**User's
Manual**

**100 MHz Universal Counter Module
WE7141**

**IM 707141-01E
3rd Edition**

Thank you for purchasing the 100 MHz Universal Counter Module WE7141 for the PC-based measurement instruments, WE7000.

This User's Manual contains useful information about the function, connection to the measuring station, and troubleshooting of the WE7141. This manual assumes that you will be using the WE7000 Control Software that is included with the measuring station.

For general information about the WE7000 (primarily the operations of the measuring station, the optical interface module, the optical interface card, and the WE7000 Control Software) see the following manual that is included with the measuring station.

Manual Title	Manual No.
WE7000 User's Manual	IM707001-01E

To ensure correct use, please read this manual thoroughly before operation. Keep this manual in a safe place for quick reference in the event a question arises.

Notes

- **The contents of this manual describe WE7000 Control Software Ver. 4.0.2.0 and module software Ver 3.03. If you are using another version of the software, the operating procedures or the figures given in this manual may differ from the actual software.**
- The contents of this manual are subject to change without prior notice as a result of continuing improvements to the instrument's performance and functions.
- Every effort has been made in the preparation of this manual to ensure the accuracy of its contents. However, should you have any questions or find any errors, please contact your nearest YOKOGAWA dealer.
- Copying or reproducing any or all of the contents of this manual without YOKOGAWA's permission is strictly prohibited.

Trademarks

- Microsoft, Windows, and Windows NT are either registered trademarks or trademarks of Microsoft Corporation in the United States and/or other countries.
- Adobe and Acrobat are trademarks of Adobe Systems Incorporated.
- Other product names are trademarks or registered trademarks of their respective holders.

Revisions

1st Edition: December 1998

2nd Edition: July 1999

3rd Edition: August 2000

Checking the Contents of the Package

Unpack the box and check the contents before operating the instrument. If the contents are not correct or missing or if there is physical damage, contact the dealer from which you purchased them.

Measurement Module

Check that the model name given on the name plate matches those on the order.

MODEL

Model	Suffix Code	Description
707141		WE7141 100 MHz Universal Counter Module
	/HE	English help message

NO.

When contacting the dealer from which you purchased the instrument, please quote the instrument No.

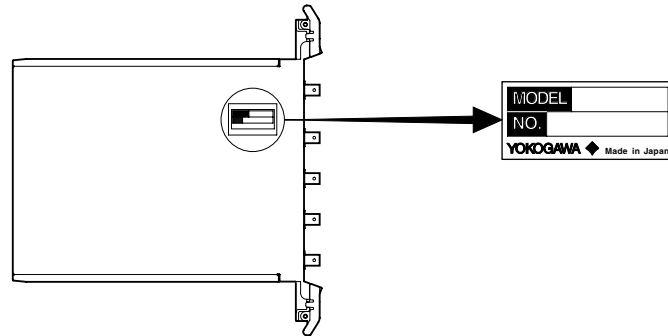

Standard Accessories

The following standard accessories are supplied with the instrument. Make sure that all items are present and undamaged.

User's Manual (1)
IM707141-01E

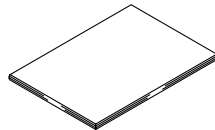

How to Use This Manual

Structure of the Manual

This User's Manual consists of the following five chapters and an index.

Chapter	Title	Description
1	Explanation of Functions	Explains the system configuration and functions.
2	Hardware Preparation	Explains how to install the module into the measuring station and how to connect the input.
3	Software Operation	Explains how to operate the software on the PC.
4	Troubleshooting and Maintenance	Explains the procedures for troubleshooting and self testing.
5	Specifications	Explains the specifications of the module.
	Index	Index of contents.

Conventions Used in This Manual

Unit

k Denotes 1000. Example: 100 kHz

K Denotes 1024. Example: 720 KB

Displayed characters

Alphanumeric characters enclosed with [] usually refer to characters or settings that are displayed on the screen.

Symbols

The following symbol marks are used to attract the operator's attention.



Affixed to the instrument. Indicates danger to personnel or to the instrument. The operator must refer to the User's Manual. The symbol is used in the User's Manual to indicate the reference.

WARNING

Describes precautions that should be observed to prevent injury or death to the user.

CAUTION

Describes precautions that should be observed to prevent minor or moderate injury, or damage to the instrument.

Note

Provides information that is important for operating the instrument properly.

Contents

Checking the Contents of the Package	2
How to Use This Manual	3
Chapter 1 Explanation of Functions	
1.1 System Configuration and Block Diagram	1-1
1.2 Measurement Parameters	1-3
1.3 Setting the Measurement Conditions	1-5
1.4 Other Functions	1-7
1.5 Measurement Accuracy	1-9
1.6 Names and Functions of Sections	1-13
Chapter 2 Hardware Preparation	
⚠ 2.1 Installing the Module into the Measuring Station	2-1
⚠ 2.2 Connecting the Cable to the Input/Output Terminals	2-3
Chapter 3 Software Operation	
3.1 Frequency Measurement	3-1
3.2 Period Measurement	3-3
3.3 Time Interval Measurement	3-4
3.4 Pulse Width Measurement	3-5
3.5 Duty Cycle Measurement	3-6
3.6 Frequency Ratio Measurement	3-7
3.7 Totalized Counting	3-8
3.8 Continuous Measurement	3-9
3.9 Operation of Other Functions	3-11
Chapter 4 Troubleshooting and Maintenance	
4.1 Troubleshooting	4-1
4.2 Self Test	4-2
4.3 Maintenance	4-3
Chapter 5 Specifications	
5.1 Input Section Specifications	5-1
5.2 Specifications of Individual Measurement Functions	5-2
5.3 External Input/Output Specifications	5-4
5.4 Default Values (Factory Default Settings)	5-5
5.5 General Specifications	5-6
5.6 Dimensional Drawings	5-8
Index	Index-1

1

2

3

4

5

Index

1.1 System Configuration and Block Diagram

The 100 MHz Universal Counter Module WE7141 is an universal counter that incorporates the reciprocal method allowing high-resolution measurement of low frequency signals. By using a multiphase clock, 10 ns time resolution is achieved.

Measurement Principle

This section explains how the 10 ns time resolution is achieved.

The timing chart of the internal clock and the input signal is shown below.

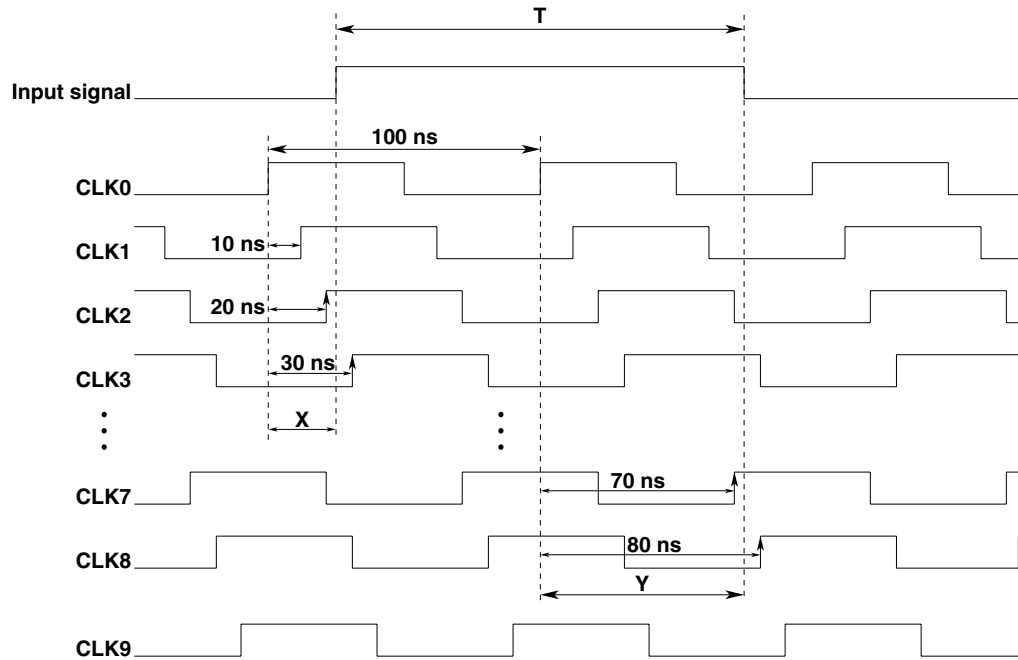

The frequency of CLK0 to CLK9 shown in the figure above is 10 MHz, with the phase of each clock shifted by 10 ns creating a 10-phase clock.

The input signal is converted to a pulse in the counter as shown in the figure. By measuring the timing of the rising and falling edges of the pulse against the 10-phase clock, a resolution higher than the frequency of the reference clock is achieved.

Because the rising edge of the input pulse is occurring between CLK2 and CLK3, the phase shift with respect to the reference clock (CLK0) is found to be

$$X = 30 \text{ ns.}$$

Similarly, because the falling edge is occurring between CLK7 and CLK8, the phase shift is found to be

$$Y = 80 \text{ ns.}$$

In the example above, time T of the input signal spans across one period of the reference clock plus the phase difference between the rising and falling edges. Therefore, time T is calculated to be

$$T = 100 \text{ ns} - 30 \text{ ns} + 80 \text{ ns} = 150 \text{ ns.}$$

By using the 10-phase clock in this way, 10 ns resolution can be achieved.

System Configuration

The following is an example in which the 100 MHz Universal Counter Module WE7141 is installed into the measuring station and the measuring station is connected to the PC with the optical fiber cable.

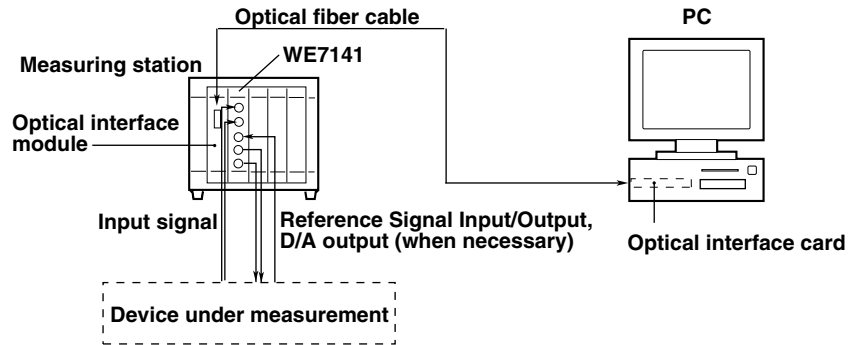

Block Diagram

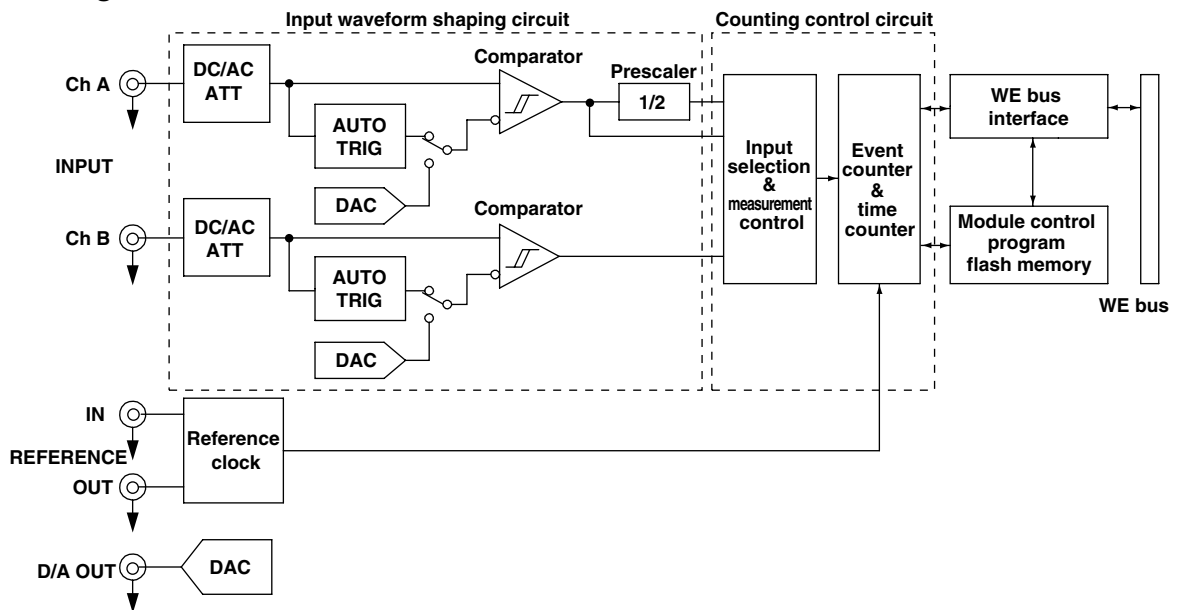

The signals that are input from channels A and B are converted to binary values by the input waveform shaping circuit and passed to the measurement control circuit. The prescaler divides the frequency of the input signal by two when making frequency measurements.

The measurement control circuit generates pulse arrays according to the specified measurement parameters and passes them to the counter.

In the counter section, the time of the pulse is measured using the 10-phase clock (see previous page) that is generated by the reference clock generation circuit. The measured value is then calculated from the time measurement. The reference clock can be switched to external input.

The D/A OUT terminal is used to output the measured value that is converted to an analog signal between 0 to 10 V.

1.2 Measurement Parameters

The following parameters can be measured on this module.

Frequency A

Measures the frequency of the input signal of channel A.

The measurement range is 1 mHz to 60 MHz or 1 Hz to 120 MHz (using the 1/2 prescaler setting).

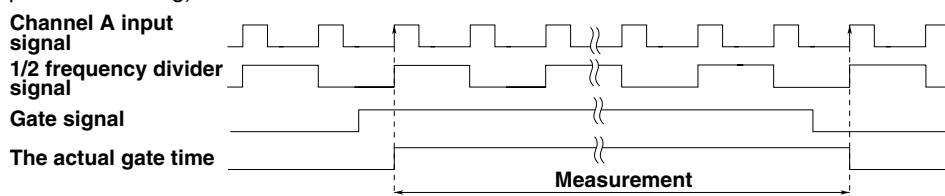

$$\text{Measurement resolution} = \frac{\pm 10 \text{ ns} \pm \sqrt{2} \times \text{Trigger error}}{\text{Gate time}} \times \text{Measurement frequency [Hz]}$$

By changing the gate time setting, you can change the measurement resolution.

Period A

Measures the period of the input signal of channel A.

The measurement range is 20 ns to 999.999999 s.

$$\text{Measurement resolution} = \frac{\pm 10 \text{ ns} \pm \sqrt{2} \times \text{Trigger error}}{10^N} \text{ [s]} \left(\begin{array}{l} 10^N \text{ is a multiplier} \\ N = 0, 1, 2, 3 \end{array} \right)$$

Time Interval A → B (T Interval A-B)

Measures the time between the rising/falling edge of the input signal of channel A and the rising/falling edge of the input signal of channel B.

The measurement range is 60 ns to 999.999999 s.

$$\text{Measurement resolution} = \frac{\pm 10 \text{ ns} \pm \text{Trigger error of channel A input} \pm \text{Trigger error of channel B input}}{\sqrt{10^N}} \text{ [s]} \left(\begin{array}{l} 10^N \text{ is a multiplier} \\ N = 0, 1, 2, 3 \end{array} \right)$$

Pulse Width A

Measures the pulse width of the input signal of channel A.

The measurement range is 20 ns to 999.999999 s.

$$\text{Measurement resolution} = \frac{\pm 10 \text{ ns} \pm \text{Trigger error of the rising edge} \pm \text{Trigger error of the falling edge}}{\sqrt{10^N}} \text{ [s]} \left(\begin{array}{l} 10^N \text{ is a multiplier} \\ N = 0, 1, 2, 3 \end{array} \right)$$

Duty Cycle A

Measures the duty cycle (pulse width/period) of the input signal of channel A.

The measurement range is 0.00000001 to 0.99999999.

$$\text{Measurement resolution} = \pm \left(\frac{\text{Pulse width} + |\text{Pulse width resolution}^*|}{\text{Period} - |\text{Period resolution}^*|} - \text{Duty measured value} \right)$$

* For the individual resolutions, see 5.2 "Specifications of Individual Measurement Functions."

Frequency Ratio A/B (Ratio A/B)

By taking one period of the input signal of channel B to be the gate, the frequency ratio is found by counting the number of pulses of the input signal of channel A.

The input frequency range is 1 mHz to 60 MHz and the measurement range is 0.001 to 999999999.

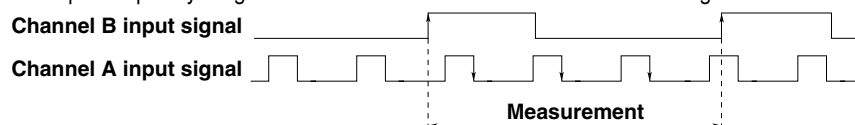

$$\text{Measurement resolution} = \frac{\pm \text{One count of channel A input} \pm \sqrt{2} \times \text{Trigger error of channel B input}}{10^N} \text{ [s]} \left(\begin{array}{l} 10^N \text{ is a multiplier} \\ N = 0, 1, 2, 3 \end{array} \right)$$

Totalize Count A (Totalize A)

Pulse occurrences of the input signal of channel A are summed. The pulses are counted by using the manual start/stop or the pulse width of the input signal of channel B as the gate. The measurement range is 0 to 10^9 .

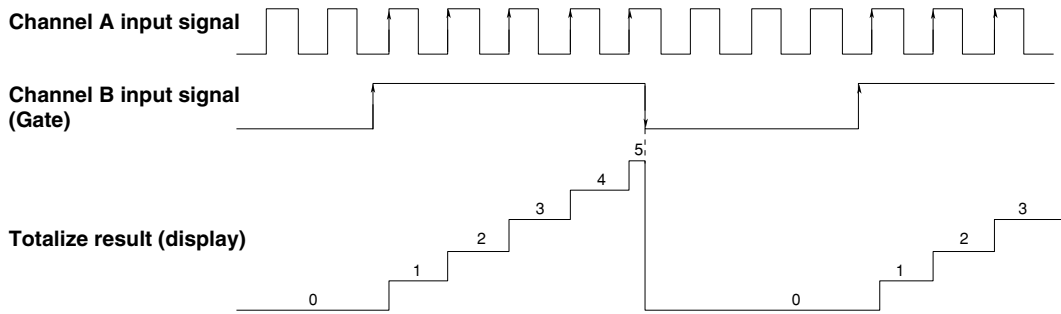

When making continuous measurements by setting the acquisition mode to [Free Run] (see page 1-7), you can also measure the totalize count difference determined by “(the current totalize count value) – (the previous totalize count value).”

1.3 Setting the Measurement Conditions

You can set the following measurement input conditions.

Input Coupling

AC

Only the AC component of the input signal is acquired. Select AC coupling when there is DC component in the signal or when the offset voltage is unstable. The lower limit of the input frequency is approximately 35 Hz.

DC

Both the AC and DC components of the input signal are acquired.

Attenuator

The trigger circuit of this module adds hysteresis to the trigger level to minimize the effects due to noise. However, if there is noise on the signal that exceeds the hysteresis width, a counting error can occur. In such cases, you can reduce the level of the input signal with the attenuator which also causes the noise to be reduced. Also, the attenuator can be used to reduce the input signal level so that it is within the operational voltage range of the unit. Voltage exceeding the operational range can produce erroneous measurements.

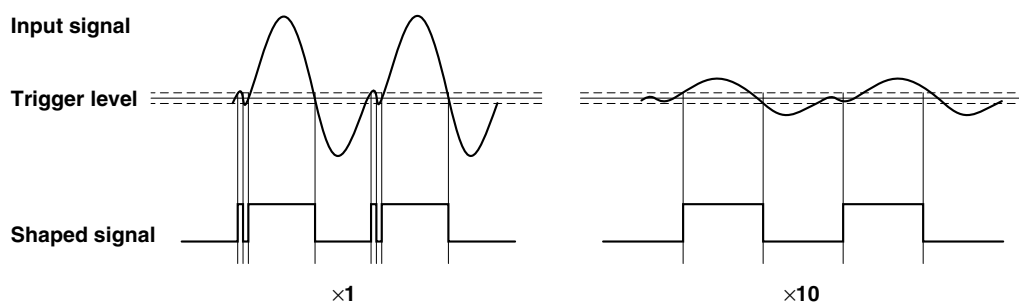

Trigger Slope

Select whether to trigger on the rising or the falling edge of the input signal

Trigger Level

Auto trigger

The center value of the amplitude of the input signal is detected, and is used as the trigger level. However, this mode is available only for sine waves with frequencies in the range from 50 Hz to 120 MHz.

Manual trigger

The trigger is activated using the specified trigger level. The setting range and the resolution vary depending on the attenuator setting as follows.

×1: Selectable range -5.00 V to 5.00 V , resolution 20 mV

×10: Selectable range -40.0 V to 40.0 V , resolution 200 mV

Prescaler (for Frequency Measurements Only)

The measurement frequency range is widened by dividing the frequency of the input signal to reduce the measurement frequency. If 1/2 prescaler is selected, the measurement range changes from (1 mHz to 60 MHz) to (1 Hz to 120 MHz).

Gate (for Frequency Measurement/Totalize Measurement Only)

In a frequency measurement, the rising and falling edges of the input signal are counted during the specified gate time, and the measurement value is found from the count number and the gate time. The longer the gate time, the larger the count number and the higher the measurement resolution. However, making the gate time longer causes the measurement period to be longer and thus the display update rate becomes slower. You can select the gate time from preset values or use the pulse width of the gate signal that is input through channel B.

In a totalize measurement, the pulses are counted by using the manual start/stop or the pulse width of the input signal of channel B.

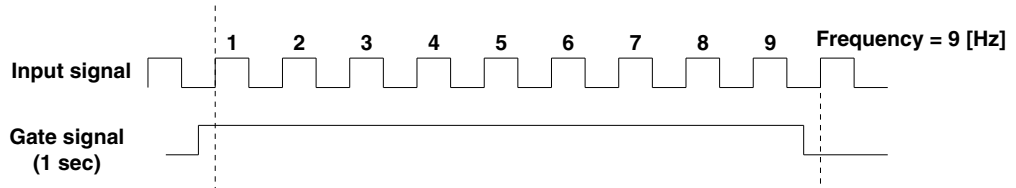

Multiplier (Other Than Frequency Measurement/Totalize Measurement)

In measurements other than the frequency measurement and the totalize measurement, the signal is measured continuously over the specified period of N and the measured value is obtained by taking the average. Therefore, the resolution increases as you make the multiplier larger. However, doing so will cause the measurement period to be longer which causes the display update rate to become slower during continuous measurements.

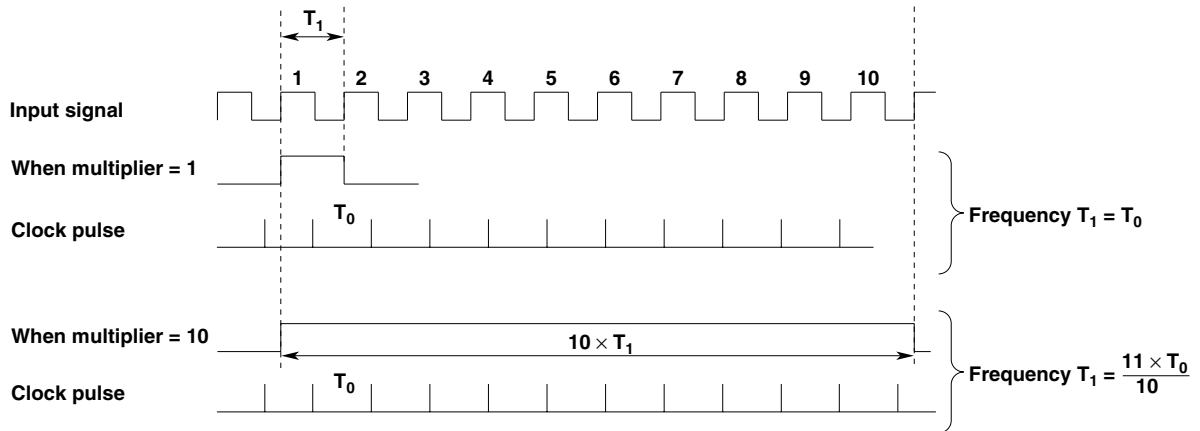

1.4 Other Functions

Selecting the Acquisition Mode

In the default acquisition mode, the module makes a measurement and then stops. This operation can be repeated. There is also another mode in which measurements can be made periodically according to the specified interval (10 ms to 100,000 s). In this mode the trend waveform based on the measured data can be displayed and saved. The former is called [One Shot] and the latter is called [Free Run]. In [Free Run], you can also measure the totalize count by measuring the difference against the previous totalize count value. The trend of the measured data is displayed on the waveform monitor that appears when the measurement is started.

Saving the Measured Data

When the acquisition mode is [Free Run], you can save the trend of the measured data displayed on the waveform monitor to a file on the PC. You can also automatically save the measured data. You can select whether to save the measured data to one file or multiple files by specifying the number of data points to save in each file.

Scaling the Measured Data

Set the measured values at any two points (VP1 and VP2) as well as their corresponding physical values (SP1 and SP2). The values at these four points define the scale conversion equation ($Y=ax+b$). The measured values are converted to physical values according to this equation, and the waveform display and saving operations are carried out.

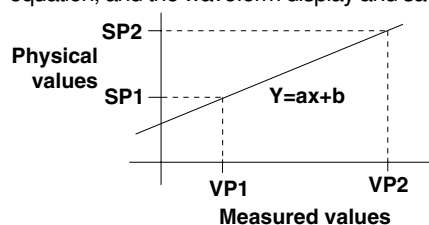

Alarm Output

When the acquisition mode is [Free Run], you can set upper and lower limits on the measured signal and can output a bus trigger signal as an alarm based on those limits to the BUSTRG1 and BUSTRG2 buses in the measuring station. You can select the alarm output condition from the following four choices.

- Rise: The measured value changes from a value below the upper limit to a value greater than or equal to the upper limit.
- Fall: The measured value changes from a value above the lower limit to a value less than or equal to the lower limit.
- In: The measured value changes from a value above the upper limit or below the lower limit to a value between the lower and upper limits.
- Out: The measured value changes from a value between the lower and upper limits to a value above the upper limit or below the lower limit.

If you, in the trigger source/time base source setting dialog box, set the WE7141 to output a bus trigger signal when an alarm occurs, the module sets the bus trigger signal to [True] for approx. 1 μ s when the alarm condition changes from an unsatisfied condition to a satisfied condition.

Arming

You can have the module start the measurement when it detects the measuring station's bus trigger signal (BUSTRG1, 2).

Controlling the Timing of the Start of the Measurement (Arming)

Besides the arming function described above, you can also control the timing of the start of a continuous measurement if the acquisition mode is [Free Run], by using the arming signal set in the trigger source/time base source/arming setting dialog box.

When the arming signal (ARM) bus is connected to the measuring module in the trigger source/time base source setting dialog box, clicking the [Start] button on the operation panel causes the module to enter the arming signal wait state. The continuous measurement starts when the arming signal becomes [True].

Holding the Displayed Value

You can hold the measured value on the display. The measurement does not stop during the time that the display is held.

External Reference Signal Input

Normally the measurement is performed using the reference signal from the internal crystal oscillator (10 MHz). However, you can set the reference signal to be an external signal that is input through the external reference signal input terminal (REFERENCE INPUT).

D/A Output

All of the measured values are converted to a voltage value (analog signal) between 0 and 10 V and are output.

Frequency output example

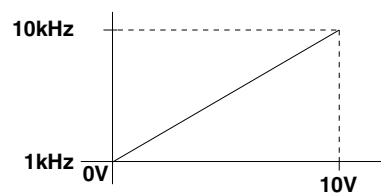

The following functions are functions of the WE7000 Control Software. For the operations of the following functions, see the on-line help that is provided with the WE7000 control Software.

Switching between Operation Panel and Monitor Panel

If you do not need to set the module, you can change the operation panel into a monitor panel that displays only the measured data as shown below.

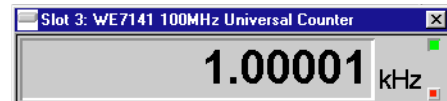

Trend Display

This function displays the waveform monitor when measured data are acquired during continuous measurement.

1.5 Measurement Accuracy

Factors That Determine the Accuracy of the Counter

Accuracy indicates how much the measured value differs from the real value. The factors that determine the accuracy are as follows.

$$\text{Accuracy} = \pm \text{resolution} + \text{time base error} \pm \text{trigger level timing error} \dots(1)$$

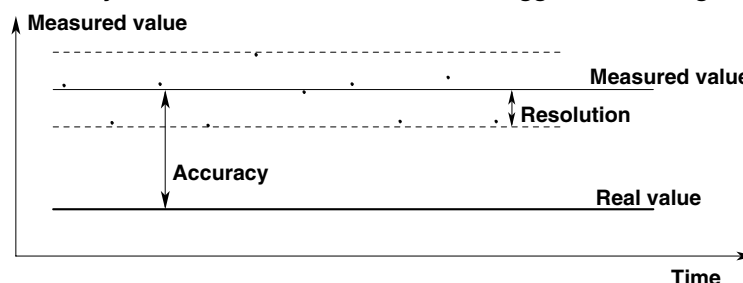

Factors That Determine the Counter Resolution

Resolution represents the minimum difference between two measurement values. The factors that comprise the resolution for the frequency and time interval measurements based on the counter are as follows.

$$\text{Resolution} = \pm 1 \text{ count error} \pm \text{trigger error} \dots (2)$$

± 1 count error

Because the internal counter clock used to measure the time and the input signal are asynchronous, a quantization error of ± 1 clock cycle can occur depending on the timing of the signals.

A clock signal and two input signals with different timings are shown below. Even though the pulse widths of signals 1 and 2 are the same, the measured values differ by 1 clock cycle due to the difference in the timing with respect to the internal clock.

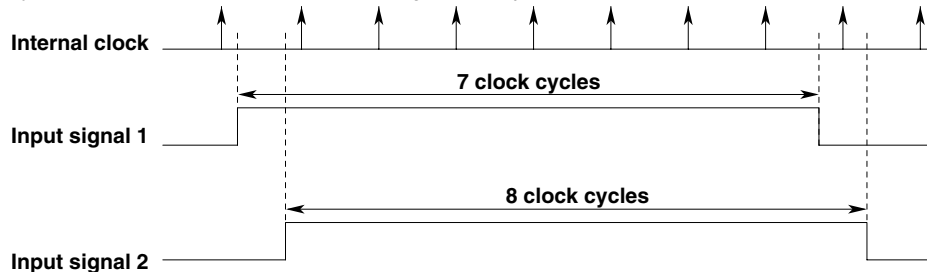

Trigger error

For input signals that have random noise or for signals with a slow rising edge, such as a low frequency sine wave, the timing of the signal crossing the trigger level changes for every measurement. This fluctuation results in a measurement error, and is called a trigger error.

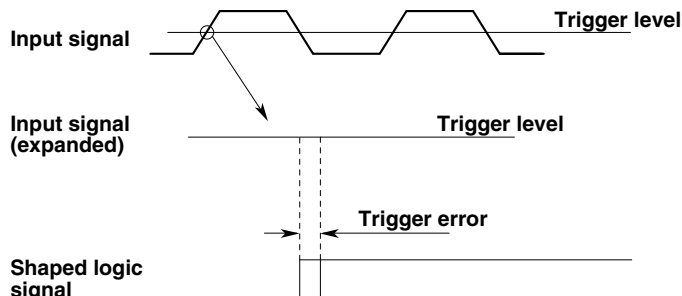

When there is noise superimposed on the input signal as shown in the figure above, the signal noise causes a trigger error for slow rising signals. The relationship between the trigger error and the signal noise using the slew rate of the signal ($SR = \Delta v / \Delta t$) is expressed as

$$\text{Trigger error [srms]} = \frac{\sqrt{X^2 + E_n^2} \text{ [V rms]}}{SR \text{ [V/s]}} \dots(3)$$

where X is the counter input section noise and E_n is the signal noise.

For this module, $X = 600 \mu\text{V rms}$ (typical value).

Gate Time and Resolution

There are two factors (± 1 count error and trigger error) in the equation expressing the resolution given on the previous page (equation 2). The ± 1 count error is ± 10 ns for this counter module. When considering a signal with a fast rising edge, the trigger error can be ignored and the resolution can be expressed in terms of only the ± 1 count error.

When measuring frequency using the gate on this counter module which utilizes the reciprocal method, the resolution is averaged by the frequency of the input signal that enters during the gate time. Thus, the resolution improves in proportion to the gate time. The resolution of the frequency measurement (± 1 count error) can be expressed as in equation (4).

$$\text{Resolution of the frequency measurement} = \frac{\pm 10 \text{ ns}}{\text{Gate time}} \times \text{Measurement frequency} \quad \dots(4)$$

This equation shows that the single-shot time resolution of 10 ns and the gate time determine the number of significant digits, and that the resolution can be found by multiplying the measurement frequency by this value.

If you set the gate time to 1 s, the number of significant digits becomes eight. The relationship between the input frequency according to the gate time and the frequency resolution (the minimum displayed digit) is shown below.

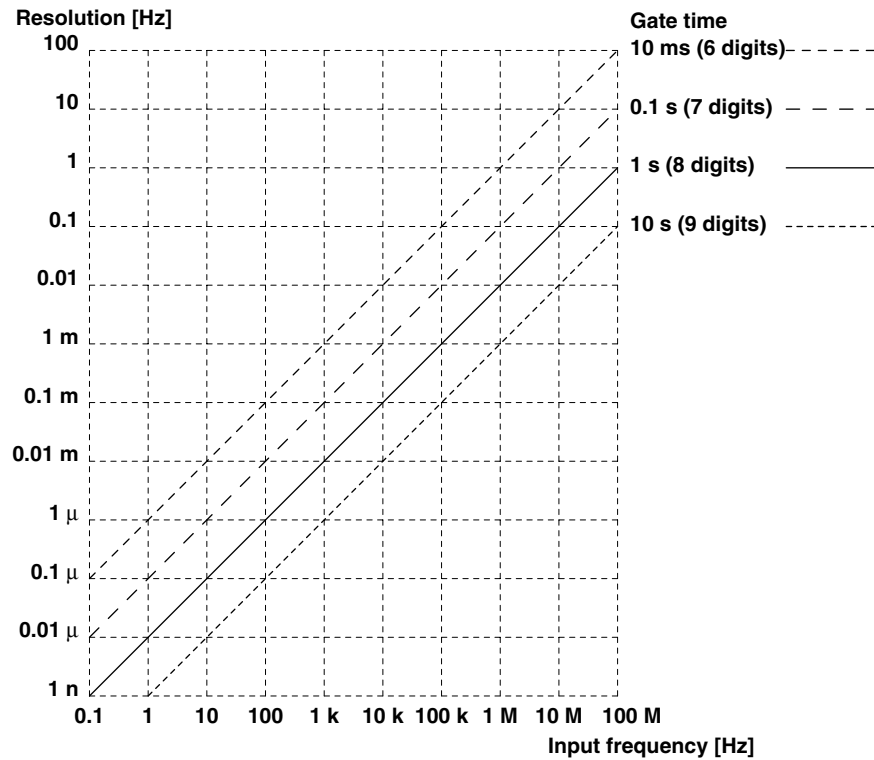

Multiplier

For measurements other than the frequency measurement, such as the period and the time interval, the resolution is improved not by using the gate, but by increasing the multiplier. In other words, the resolution is increased by measuring the time of N continuous periods and taking the average. The time charts of the period, pulse width, time interval, and duty cycle measurements using a multiplier of 10 are shown below.

For period measurement

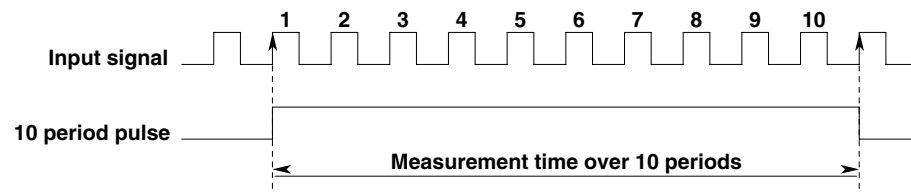

For pulse width, time interval, and duty cycle measurements

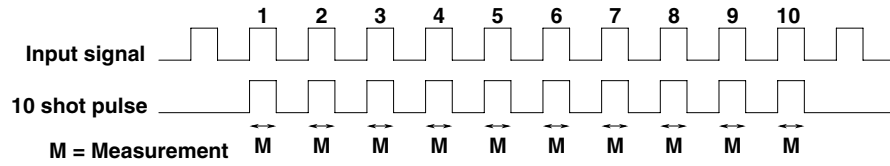

If the multiplier is set to 10 for period measurements, the measurement is made across 10 input pulses. The edges are only measured at the first and the eleventh pulses and, therefore, the average is found by simply dividing by ten. Because the errors from measuring the edges are reduced during this period, the resolution improves by a factor of ten. However, for time interval, pulse width, and duty cycle measurements, the 10 pulses are measured individually and then averaged. Therefore, the resolution does not improve by a factor of ten, but rather only improves by $\sqrt{10}$ because the value is an average of 10 independent pulses.

Time Base Error

The oscillation period of the internal crystal oscillator is the time reference for the measurements.

The oscillation frequency of the crystal oscillator deteriorates with age. The aging rate of the crystal oscillator for this module is given by

$$\pm 1.5 \times 10^{-6}/\text{yr}$$

Therefore, the frequency of the 10 MHz oscillator can change up to 15 Hz after one year. The error caused by this shifting of the reference frequency is called a time base error.

Frequency deviation [Hz]

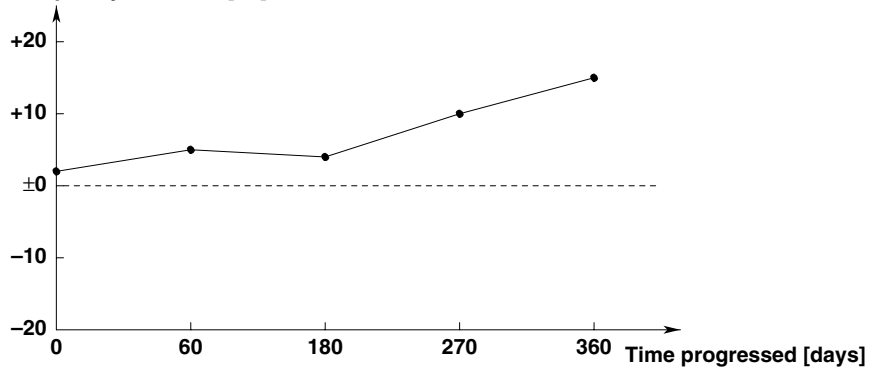

Trigger Level Timing Error

The trigger level timing error occurs during time interval, pulse width, and duty cycle measurements. The error is caused by the setting accuracy of the trigger level, the difference between the inputs of channels A and B, and the variation of the rising and falling characteristics among the different probes.

The following is an example of a time interval measurement. For reducing the effects due to noise, the trigger level has a hysteresis. Unfortunately, this causes a timing error, because the trigger is activated at a higher voltage level than that which is specified. If the signal rises slowly, the trigger is delayed by the amount of the hysteresis width.

In addition, if the rising times of start and stop are different, the trigger level setting accuracy causes a timing error. The combined error caused by the hysteresis width and the trigger level setting accuracy is called a trigger level timing error. If the rising time is expressed in terms of the signal's slew rate (SR [V/μs]), the trigger level timing error can be computed using the following equation.

$$\text{Trigger level timing error} = \left(\frac{\frac{1}{2} \text{ hysteresis width}^*}{\text{SR (Start)}} - \frac{\frac{1}{2} \text{ hysteresis width}^*}{\text{SR (Start)}} \right) \pm \frac{\text{Trigger level setting frequency}}{\text{SR (Start)}} \pm \frac{\text{Trigger level setting frequency}}{\text{SR (Stop)}}$$

where SR: Input signal's slew rate at the trigger level

* When the attenuator setting is $\times 1$, the hysteresis width is 20 mV.

1.5 Measurement Accuracy

Because the rising time of the input signal of channel B is slower than that of channel A, the measured time interval becomes the following.

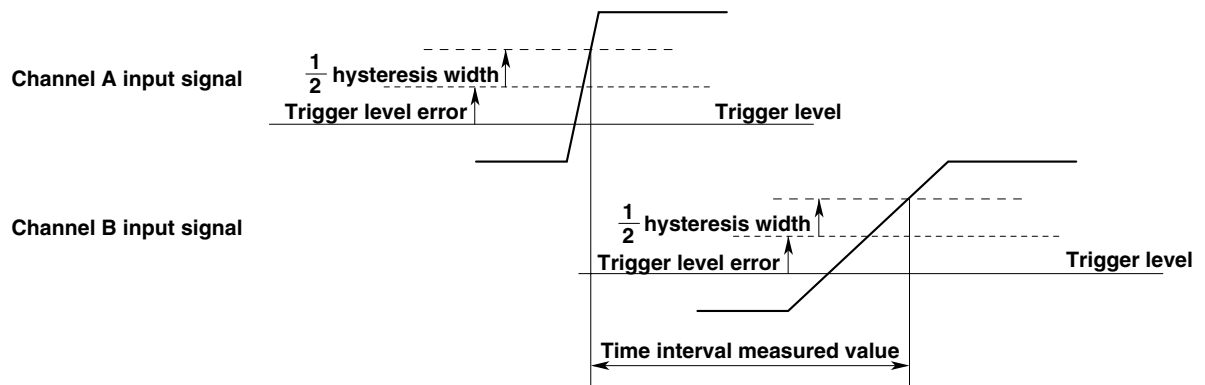

1.6 Names and Functions of Sections

Front Panel

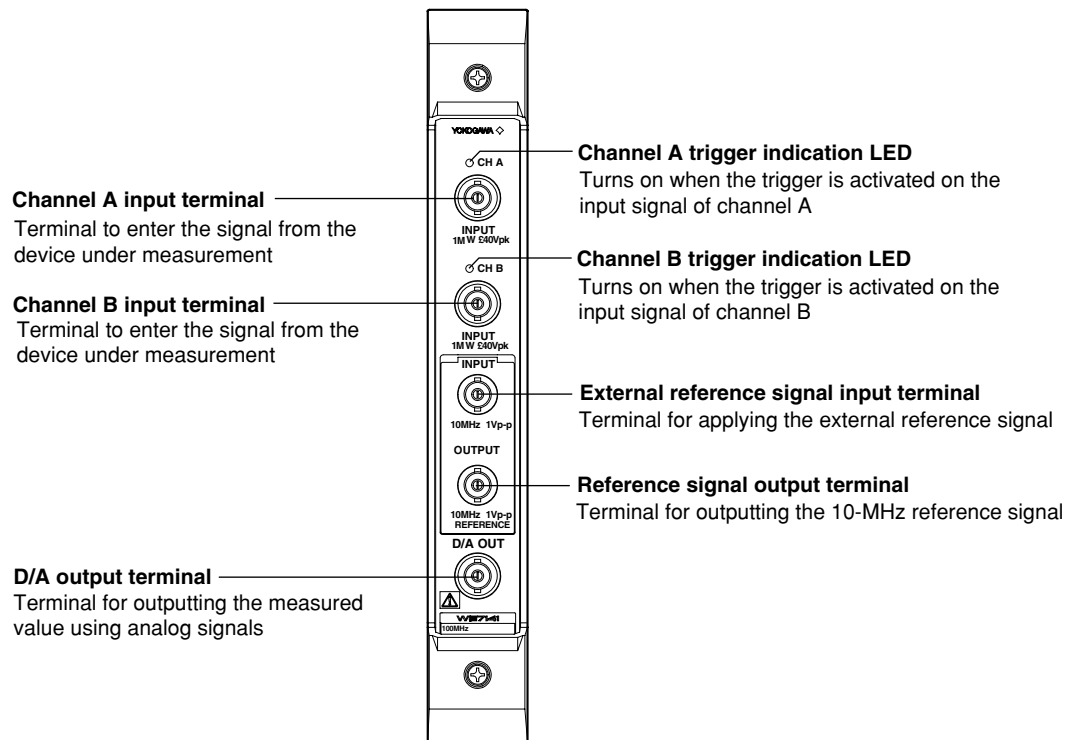

2.1 Installing the Module into the Measuring Station

Preparing to Install the Module

The measuring station comes with each slot covered with a cover plate as shown in the figure below. Verify that the power supply is not connected to the measuring station, then loosen the module attachment screws (2 locations) and remove the cover plate from the slot where the module is going to be installed. Please note that the slot on the left end is dedicated to the communication interface module and therefore this module cannot be installed there.

* The following figure shows an example of the measuring station WE400.

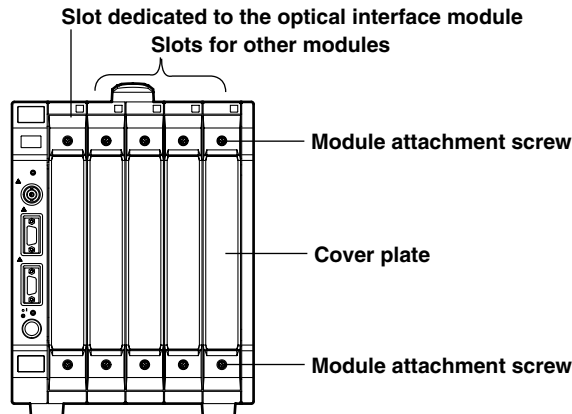

Installing the Digital Thermometer Module



WARNING

- Make sure to fasten the top and bottom attachment screws. If you connect the input signal cable without fastening the attachment screws, the protective grounding of the measurement module provided by the power cord is compromised and may cause electric shock.



CAUTION

- To avoid damaging the instrument when installing modules, make sure to turn OFF the standby power switch of the measuring station.
- Be careful not to get your fingers caught in the ejection lever when inserting the module. In addition, do not put your hand inside the slot, because there are protrusions along the module guide that may injure your fingers.
- Do not remove the cover plates from unused slots. It can cause overheating and malfunction. The cover plates are also needed to minimize the influence of electromagnetic interference.

Insert the module along the guide rail of the slot from which you removed the cover plate. Insert the module until it clicks into the connector. Be careful not to get your fingers caught in the ejection lever while inserting the module. When the module is securely inserted, fasten the module attachment screws (tightening torque: 0.6 to 0.7 N·m).

To remove the module, loosen the module attachment screws and pull the ejection lever from the inside to the outside. This will force the module out of the slot.

<There is an illustration on the next page.>

2.1 Installing the Module into the Measuring Station

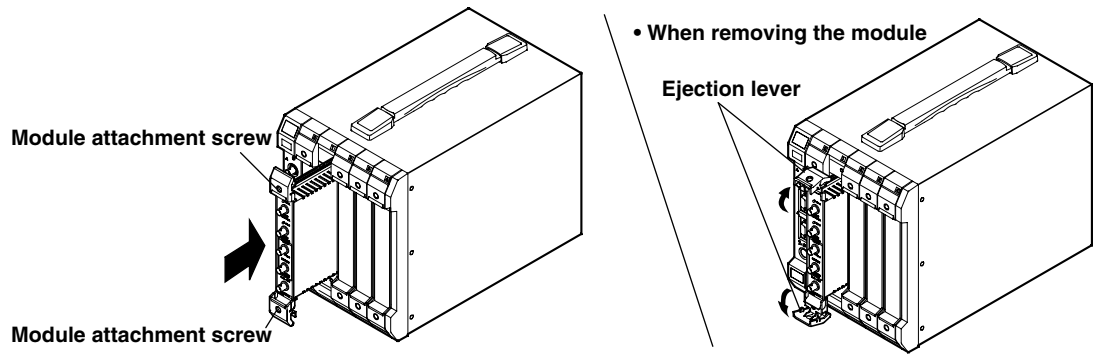

2.2 Connecting the Cable to the Input/Output Terminals

Connecting the Input

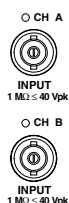

Connect the BNC cable to the input terminal (INPUT CH A, CH B) on the front panel of the module. The channel B terminal is used only during time interval A → B and frequency ratio A/B measurements and when inputting the gate signal.

- Number of input channels: 2 (A, B)
- Input format: Non-isolated unbalanced
- Input impedance: 1 MΩ//40 pF (Typical value)
- Operation voltage range: ±5 V (when attenuator set to ×1)
- Maximum input voltage: 40 V (DC + ACpeak)
 - DC ≤ input frequency < 4 MHz,
 - 140/f [MHz] +5 [V (DC + ACpeak)] 4 MHz ≤ input frequency < 120 MHz
 - (Overvoltage Category: CAT I and II)
- Minimum input pulse: 10 ns (except when using 1/2 prescaler)
- * When applying frequency A or the gate signal (during totalize count) to channel B, follow the restrictions below.
 - The pulse width of the gate signal is between 100 ns and 100 s.
 - The number of input cycles of channel A within the gate time does not exceed 2³² counts.
 - Gate time of channel B > One period of the input signal of channel A



CAUTION

- Do not apply a voltage exceeding the maximum input voltage indicated above, as it may damage the module.

Note

- When measuring high frequency signals, the input impedance becomes very small because of the parallel capacitance of the input. If the input signal level is low, the measurements may not be performed correctly. In this case, use the commercially sold FET probe with small input capacitance. Note that when using the FET probe, you will also need a 50 Ω terminator (Model: 700976).
- On high frequency signals or pulse signals with fast rising times, the signal source impedance (including the impedance of the cable) and the input impedance of the module may be mismatched causing reflections that distort the waveform. In addition, the input capacitance of the module and the capacitance of the connected cable sometimes cause resonance. In these cases, correct measurements cannot be made unless the signal source impedance and the impedance of the module are made to match.
- When measuring the time interval of channels A and B in the ns order, the difference in the cable length will lead to measurement errors. In this case, make the lengths of the cables the same, or measure the difference of the cable lengths beforehand, and correct the measurement results accordingly.

External Reference Signal Input



When using an external reference signal in place of the internal crystal oscillator (10 MHz), connect a BNC cable to the external reference signal input terminal (REFERENCE INPUT) on the front panel of the module. Apply a signal that adheres to the following specifications.

- Input impedance: 1 kΩ or more
- Input frequency range: 10 MHz ±10 Hz
- Input level: 1 Vp-p or more
- Maximum input voltage: ±10 V (Overvoltage Category: CAT I and II)



CAUTION

- Do not apply a voltage exceeding the maximum input voltage indicated above, as it may damage the module.

Input Section Circuit Diagram

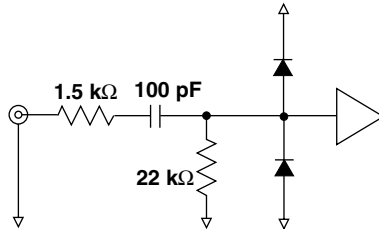

Reference Signal Output



The reference signal is output from the reference signal output terminal (REFERENCE OUTPUT) on the front panel of the module according to the following specifications.

- Output impedance: 50 Ω (Typical value)
- Output frequency: 10 MHz (Typical value)
- Output level: 1 V p-p or more (with 50 Ω load)
- Connector type: BNC



CAUTION

- Do not short the output terminal, or apply an external voltage to it, as damage to the module may result.
- Make sure to connect the ground side of the output terminal to the ground of the connected device. Otherwise, damage to the connected device may result.

Output Section Circuit Diagram

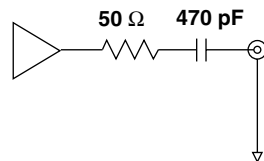

D/A Output



When outputting the measured values as an analog signal, connect a BNC cable to the D/A output terminal (D/A OUT) on the front panel of the module.

- Output voltage range: 0 to +10 V (with high impedance load) linear conversion
- Maximum output current: ±2 mA
- Output format: Non-isolated unbalanced
- Connector type: BNC

3.1 Frequency Measurement

You will be using the operation panel that appears by double-clicking the module icon in the station list window as shown in the figure below.

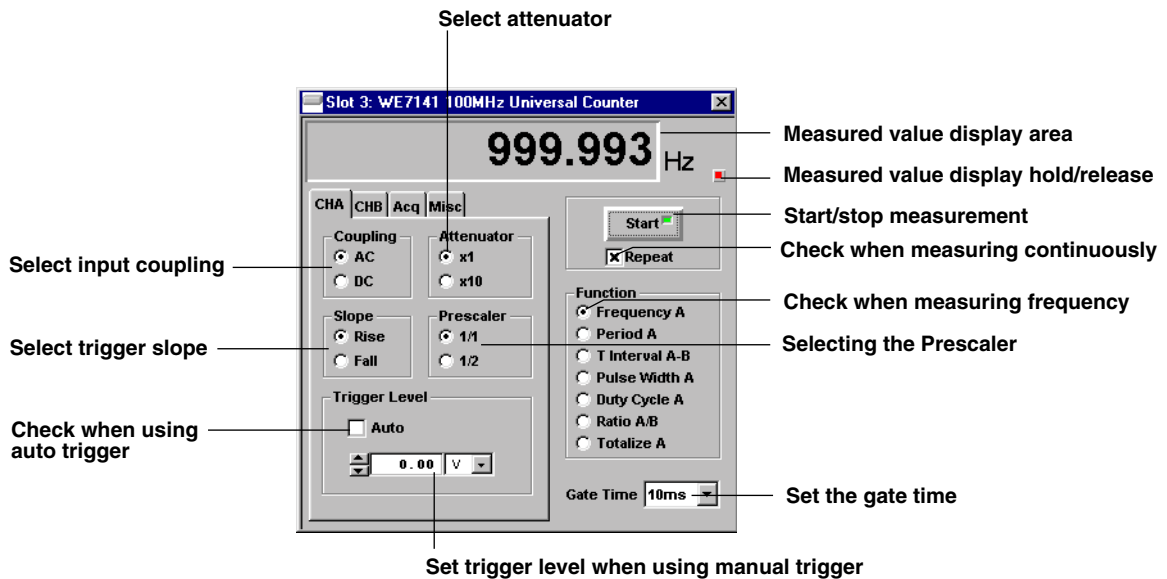

Selecting the Measurement Parameter

Select [Frequency A] under the [Function] option buttons.

Selecting the Input Coupling

Select either [AC] or [DC] under the [Coupling] option buttons.

Selecting the Attenuator

Select either [×1] or [×10] under the [Attenuator] option buttons.

Selecting the Trigger Slope

Select the trigger slope under the [Slope] option buttons. Select from the following options.

Rise: Rising edge

Fall: Falling edge

Selecting the Trigger Level

Check [Auto] when auto triggering is desired. When using the manual trigger, uncheck [Auto] and enter a value in the value entry box.

The selectable ranges and resolutions are as follows. Select [V] or [mV] for the unit of measurement.

When attenuator is set to ×1: −5 V to +5 V (resolution: 20 mV)

When attenuator is set to ×10: −40 V to +40 V (resolution: 200 mV)

Selecting the Prescaler

Select either [1/1] or [1/2] under the [Prescaler] option buttons. The measurement range changes depending on the prescaler setting as follows.

1/1: 1 mHz to 60 MHz

1/2: 1 Hz to 120 MHz

Setting the Gate Time

Select the gate time from the [Gate Time] list box. The gate time can be set to [10ms], [100ms], [1s], [10s], or [Ext].

To control the gate time by applying a gate signal to channel B (CH B), select [Ext]. However, you cannot select prescaler 1/2 on the gate signal of channel B (CH B).

For the procedures to input the gate signal, see page 2-3.

3.2 Period Measurement

You will be using the operation panel that appears by double-clicking the module icon in the station list window as shown in the figure below.

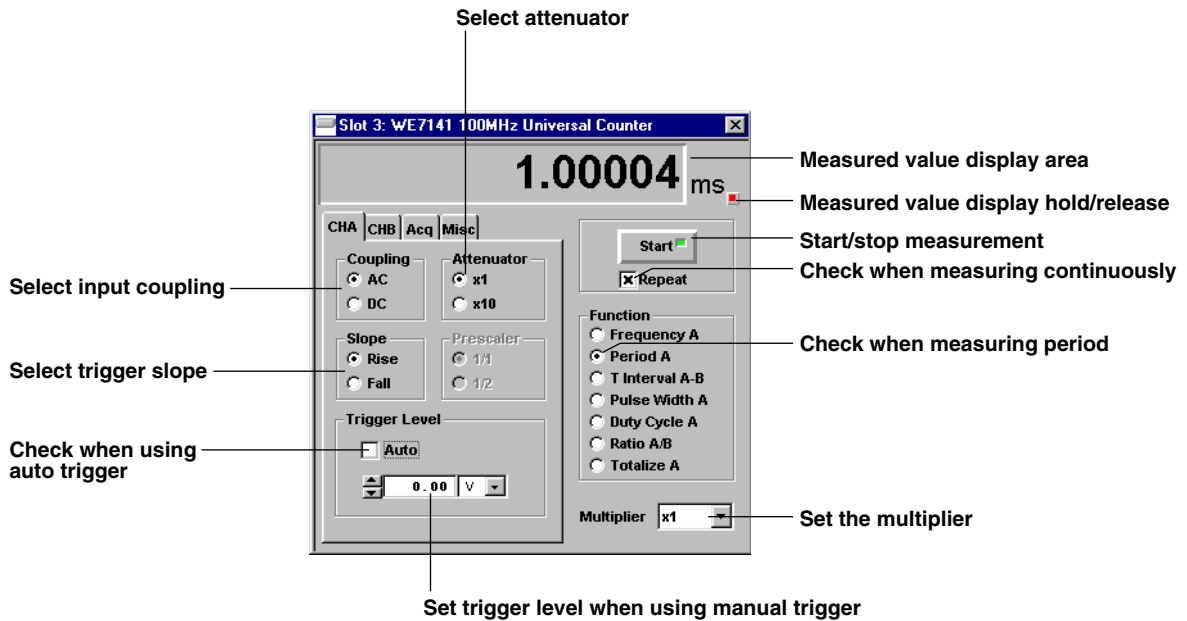

Selecting the Measurement Parameter

Select [Period A] under the [Function] option buttons.

Selecting the Input Coupling

Select either [AC] or [DC] under the [Coupling] option buttons.

Selecting the Attenuator

Select either [x1] or [x10] under the [Attenuator] option buttons.

Selecting the Trigger Slope

Select the trigger slope under the [Slope] option buttons. Select from the following options.

Rise: Rising edge

Fall: Falling edge

Selecting the Trigger Level

Check [Auto] when auto triggering is desired. When using the manual trigger, uncheck [Auto] and enter a value in the value entry box.

The selectable ranges and resolutions are as follows. Select [V] or [mV] for the unit of measurement.

When attenuator is set to x1: -5 V to +5 V (resolution: 20 mV)

When attenuator is set to x10: -40 V to +40 V (resolution: 200 mV)

Setting the Multiplier

Select the multiplier from the [Multiplier] list box. The multiplier can be set to [x1], [x10], [x100], or [x1000].

3.3 Time Interval Measurement

You will be using the operation panel that appears by double-clicking the module icon in the station list window as shown in the figure below.

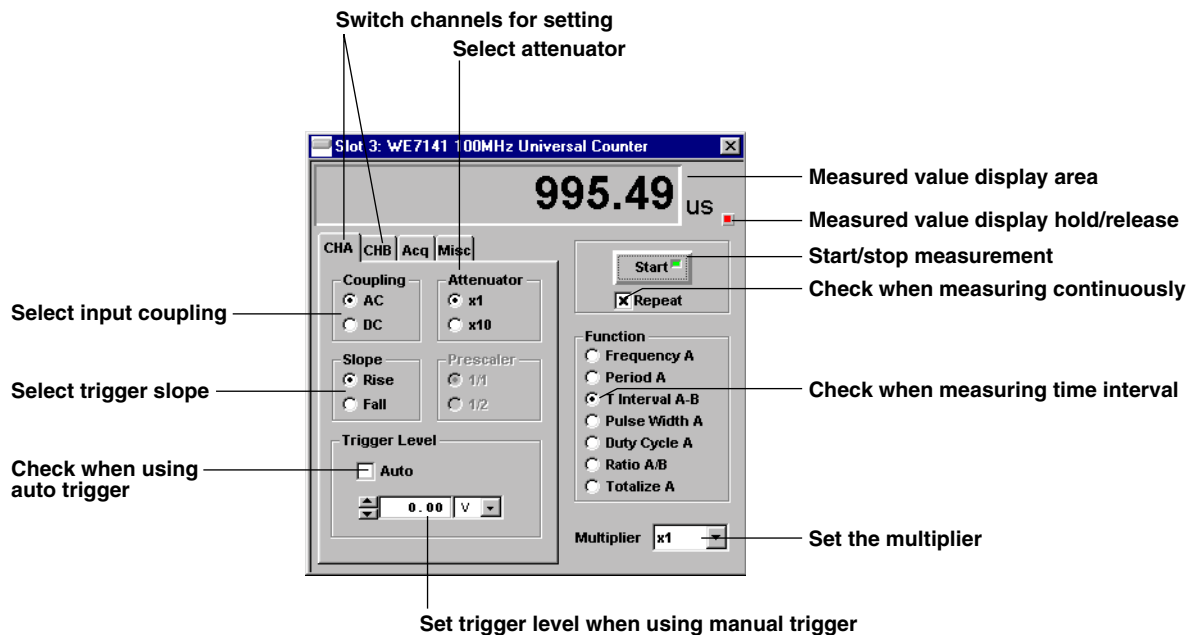

Selecting the Measurement Parameter

Select [T Interval A-B] under the [Function] option buttons.

Selecting the Input Coupling

Select either [AC] or [DC] under the [Coupling] option buttons. Select for both channels A and B.

Selecting the Attenuator

Select either [x1] or [x10] under the [Attenuator] option buttons. Select for both channels A and B.

Selecting the Trigger Slope

Select the trigger slope under the [Slope] option buttons. Select from the following options. Select for both channels A and B.

Rise: Rising edge

Fall: Falling edge

Selecting the Trigger Level

Check [Auto] when auto triggering is desired. When using the manual trigger, uncheck [Auto] and enter a value in the value entry box.

The selectable ranges and resolutions are as follows. Select [V] or [mV] for the unit of measurement. Select for both channels A and B.

When attenuator is set to x1: -5 V to +5 V (resolution: 20 mV)

When attenuator is set to x10: -40 V to +40 V (resolution: 200 mV)

Setting the Multiplier

Select the multiplier from the [Multiplier] list box. The multiplier can be set to [x1], [x10], [x100], or [x1000].

3.4 Pulse Width Measurement

You will be using the operation panel that appears by double-clicking the module icon in the station list window as shown in the figure below.

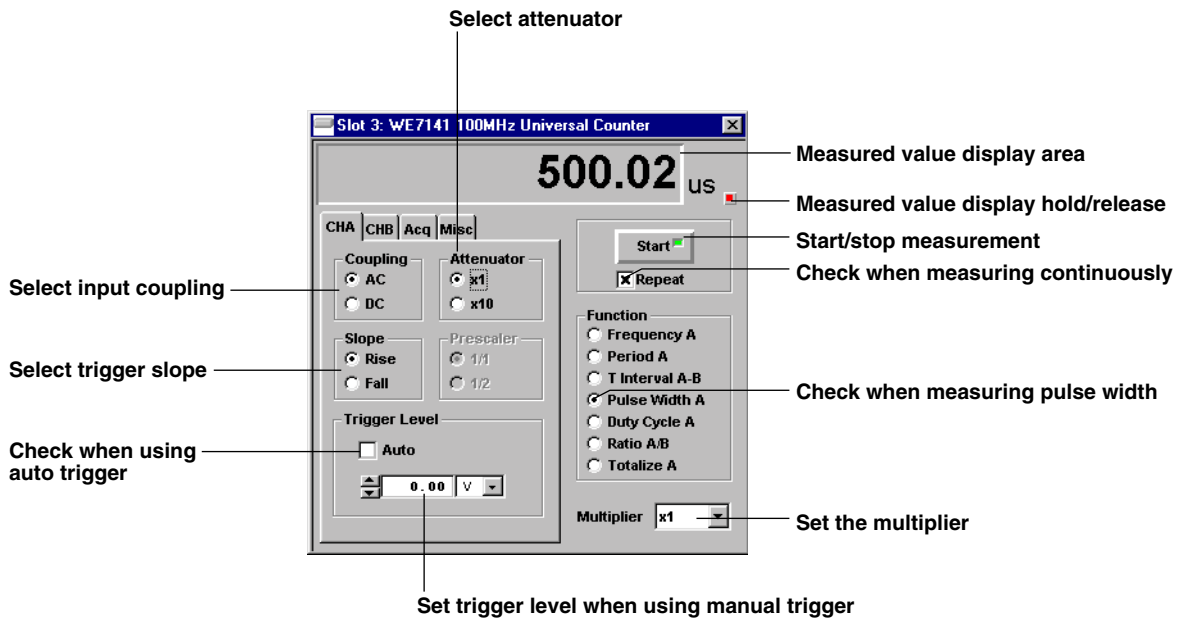

Selecting the Measurement Parameter

Select [Pulse Width A] under the [Function] option buttons.

Selecting the Input Coupling

Select either [AC] or [DC] under the [Coupling] option buttons.

Selecting the Attenuator

Select either [x1] or [x10] under the [Attenuator] option buttons.

Selecting the Trigger Slope

Select the trigger slope under the [Slope] option buttons. Select from the following options.

Rise: Rising edge

Fall: Falling edge

Selecting the Trigger Level

Check [Auto] when auto triggering is desired. When using the manual trigger, uncheck [Auto] and enter a value in the value entry box.

The selectable ranges and resolutions are as follows. Select [V] or [mV] for the unit of measurement.

When attenuator is set to x1: -5 V to +5 V (resolution: 20 mV)

When attenuator is set to x10: -40 V to +40 V (resolution: 200 mV)

Setting the Multiplier

Select the multiplier from the [Multiplier] list box. The multiplier can be set to [x1], [x10], [x100], or [x1000].

3.5 Duty Cycle Measurement

You will be using the operation panel that appears by double-clicking the module icon in the station list window as shown in the figure below.

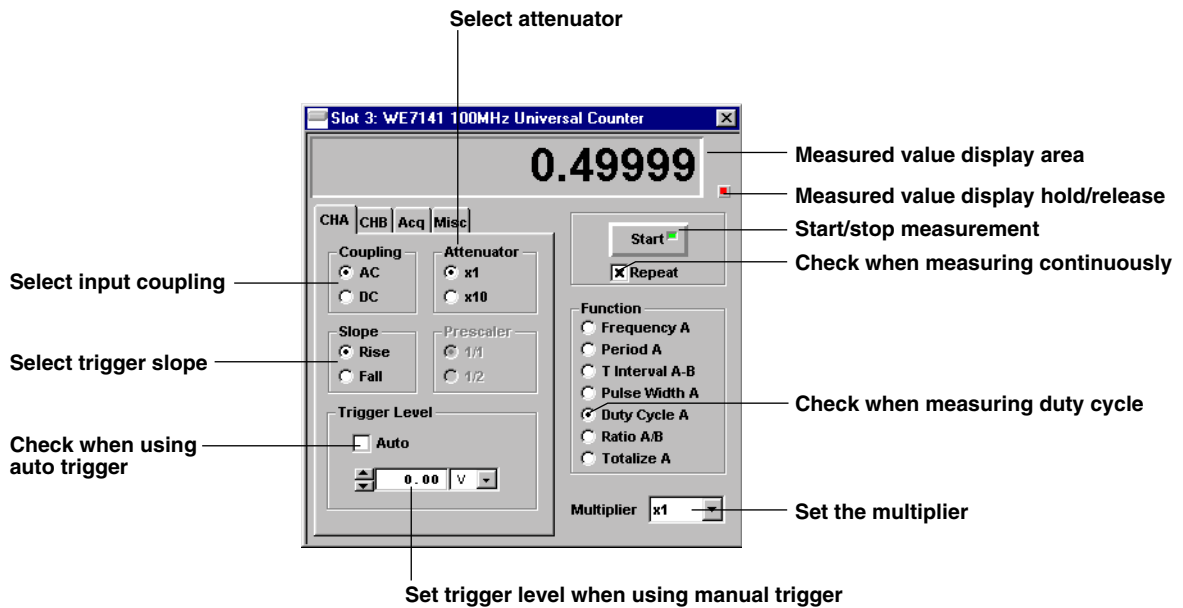

Selecting the Measurement Parameter

Select [Duty Cycle A] under the [Function] option buttons.

Selecting the Input Coupling

Select either [AC] or [DC] under the [Coupling] option buttons.

Selecting the Attenuator

Select either [x1] or [x10] under the [Attenuator] option buttons.

Selecting the Trigger Slope

Select the trigger slope under the [Slope] option buttons. Select from the following options.

Rise: Rising edge

Fall: Falling edge

Selecting the Trigger Level

Check [Auto] when auto triggering is desired. When using the manual trigger, uncheck [Auto] and enter a value in the value entry box.

The selectable ranges and resolutions are as follows. Select [V] or [mV] for the unit of measurement.

When attenuator is set to x1: -5 V to +5 V (resolution: 20 mV)

When attenuator is set to x10: -40 V to +40 V (resolution: 200 mV)

Setting the Multiplier

Select the multiplier from the [Multiplier] list box. The multiplier can be set to [x1], [x10], [x100], or [x1000].

3.6 Frequency Ratio Measurement

You will be using the operation panel that appears by double-clicking the module icon in the station list window as shown in the figure below.

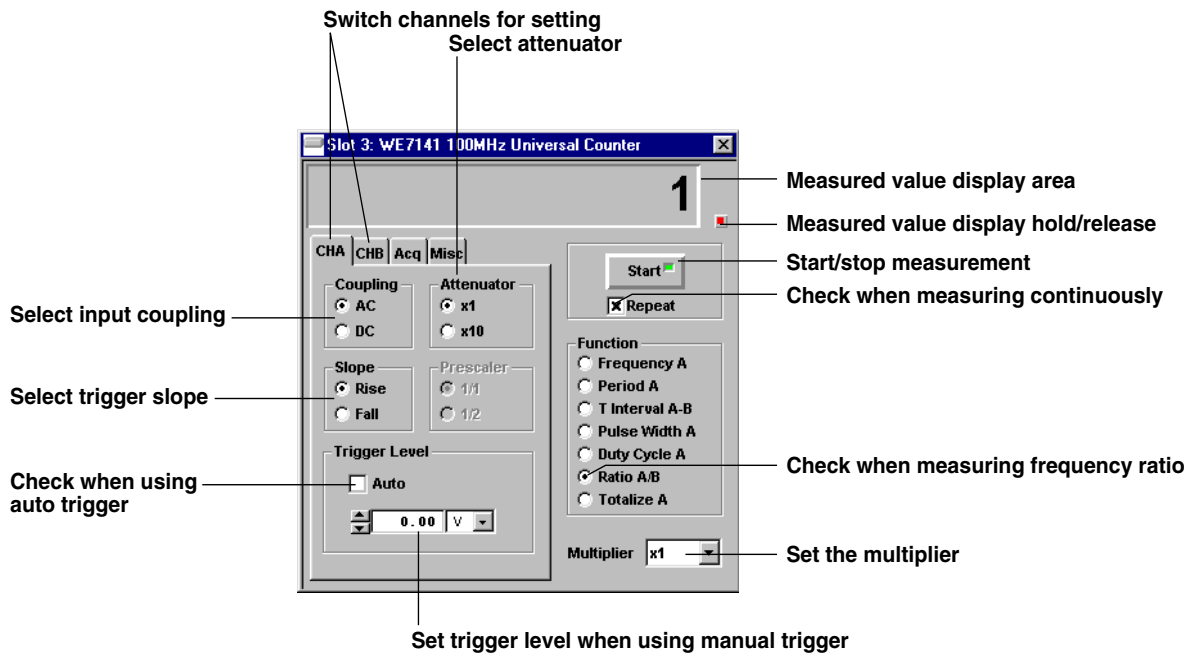

Selecting the Measurement Parameter

Select [Ratio A/B] under the [Function] option buttons.

Selecting the Input Coupling

Select either [AC] or [DC] under the [Coupling] option buttons. Select for both channels A and B.

Selecting the Attenuator

Select either [x1] or [x10] under the [Attenuator] option buttons. Select for both channels A and B.

Selecting the Trigger Slope

Select the trigger slope under the [Slope] option buttons. Select from the following options. Select for both channels A and B.

Rise: Rising edge

Fall: Falling edge

Selecting the Trigger Level

Check [Auto] when auto triggering is desired. When using the manual trigger, uncheck [Auto] and enter a value in the value entry box.

The selectable ranges and resolutions are as follows. Select [V] or [mV] for the unit of measurement. Select for both channels A and B.

When attenuator is set to x1: -5 V to +5 V (resolution: 20 mV)

When attenuator is set to x10: -40 V to +40 V (resolution: 200 mV)

Setting the Multiplier

Select the multiplier from the [Multiplier] list box. The multiplier can be set to [x1], [x10], [x100], or [x1000].

3.7 Totalized Counting

You will be using the operation panel that appears by double-clicking the module icon in the station list window as shown in the figure below.

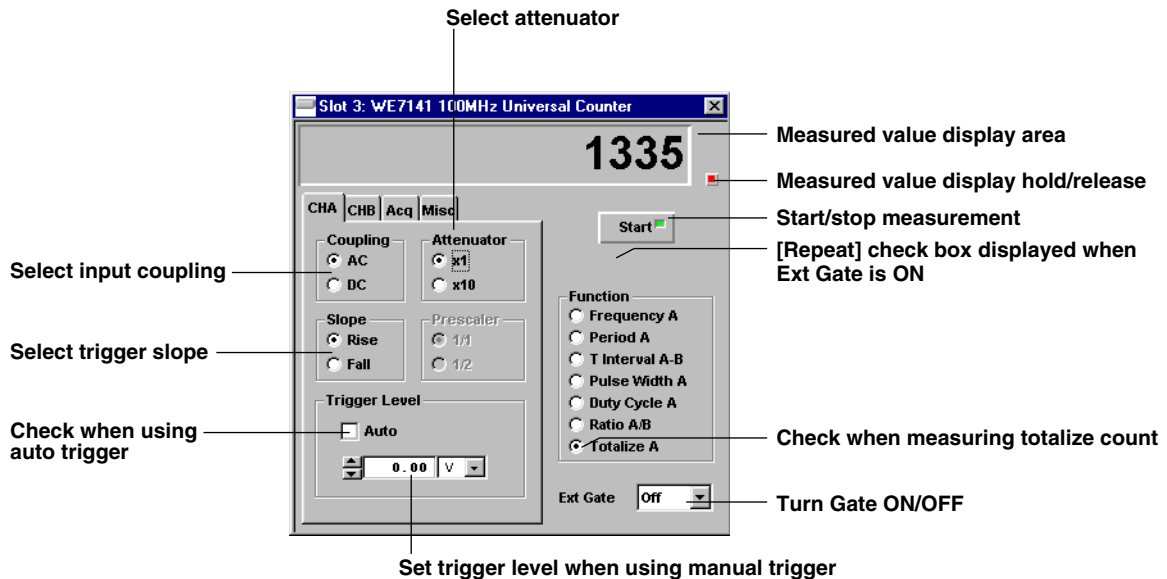

Selecting the Measurement Parameter

Select [Totalize A] under the [Function] option buttons.

Selecting the Input Coupling

Select either [AC] or [DC] under the [Coupling] option buttons.

Selecting the Attenuator

Select either [x1] or [x10] under the [Attenuator] option buttons.

Selecting the Trigger Slope

Select the trigger slope under the [Slope] option buttons. Select from the following options.

Rise: Rising edge

Fall: Falling edge

Selecting the Trigger Level

Check [Auto] when auto triggering is desired. When using the manual trigger, uncheck [Auto] and enter a value in the value entry box. The selectable ranges and resolutions are as follows. Select [V] or [mV] for the unit of measurement.

When attenuator is set to x1: -5 V to +5 V (resolution: 20 mV)

When attenuator is set to x10: -40 V to +40 V (resolution: 200 mV)

Selecting Gate ON/OFF

Select [On] or [Off] with the [Ext Gate] list box. To gate control the counter by applying a gate signal to channel B (CH B), select [On]. For the procedures to input the gate signal, see page 2-3.

Note

- The counter range is 0 to 10⁹.
- The counting operation continues even if you hold the counter display value.
- If you set the acquisition mode to [Free Run], you can measure the totalize count difference determined by “(the current totalize count value) – (the previous totalize count value)” (see next page).

3.8 Continuous Measurement

Selecting the Acquisition Mode and Setting the Sampling Interval

You will use the operation panel that appears by double-clicking the Acq tab.

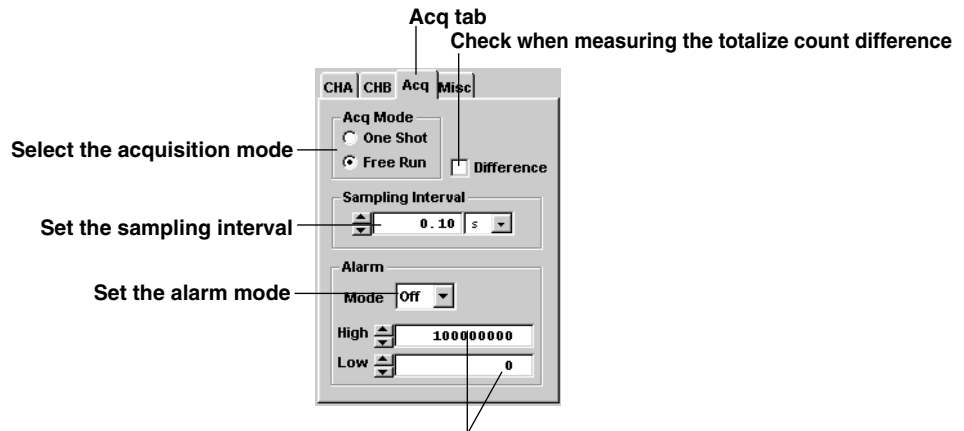

When specifying the sampling interval and making continuous measurements, select [Free Run] with the [Acq Mode] option button. The sampling interval can be set in the range "10 ms to 100,000 s" (in 10 ms steps). The default value is 100 ms. When making continuous measurements in [Free Run] mode, the waveform monitor displays the trend waveform. For the operating procedures of the trend waveform display on the waveform monitor, see the on-line help that is provided with the WE7000 control Software. In addition, a waveform monitor ON/OFF button is displayed to the right of the [Start] button as shown below. If the waveform monitor is turned OFF with this button, the waveform monitor will not be displayed when the measurement is started.



Measuring the totalize count difference

The [Difference] check box becomes selectable when making continuous measurements using the totalize measurement. When checked, the totalize count difference determined by "(the current totalize count value) – (the previous totalize count value)" is measured. The initial value displays "the current totalize count value."

Setting the Scale Conversion

Selecting [Convert Scale] from the menu that appears by right-clicking the module icon in the station list window displays a dialog box as shown below. If you wish to convert the scale of the waveform display as well as save the converted data, check the [Save Physical Values] box, check the box to the left of the channel number [CH1], and enter the scale values (VP1, SP1, VP2, SP2), Label and unit. If you do not check the [Save Physical Values] box, the waveform display will be converted, but raw data will be saved to the file. If the [Save Physical Value] box is checked, but the box to the left of the channel number [CH1] is not checked, raw data will be used for both displaying and saving. For the explanation of the scale conversion expression, see "Scaling the Measured Data" in section 1.4, "Other Functions."

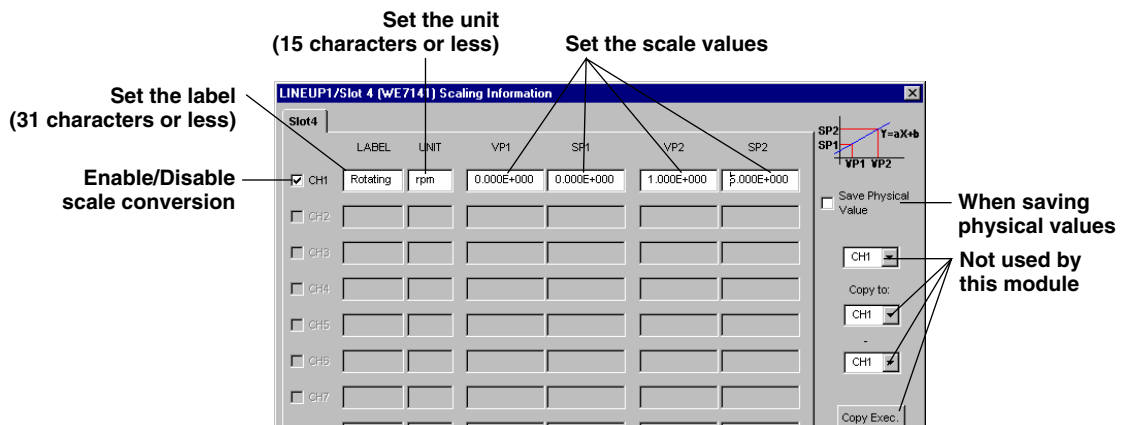

Saving Measured Data during Continuous Measurement

Select [Save Acquisition Data] in the menu that appears by right-clicking the module icon that is to save the measurement data in the station list window. Set the save conditions in the displayed dialog box. For details, see section 4.8, in the WE7000 User's Manual (IM707001-01E).

Selecting the Alarm Mode and Setting the Alarm's Upper and Lower Limits

Select on what condition an alarm should be generated. Use the operation panel that appears by clicking the Acq tab if you are outputting an alarm during continuous measurement in the [Free Run] mode (see page 3-9). Use the [Mode] list box if you are generating an alarm (bus trigger) signal based on the specified upper and lower limits. The range of values that the upper and lower limits can take is "0 to 1,000,000,000."

Rise: The measured value changes from a value below the upper limit to a value greater than or equal to the upper limit.

Fall: The measured value changes from a value above the lower limit to a value less than or equal to the lower limit.

In: The measured value changes from a value above the upper limit or below the lower limit to a value between the lower and upper limits.

Out: The measured value changes from a value between the lower and upper limits to a value above the upper limit or below the lower limit.

3.9 Operation of Other Functions

For the following operations, you will use the operation panel that appears by clicking the Misc tab except for “Setting the start timing of the measurement.”

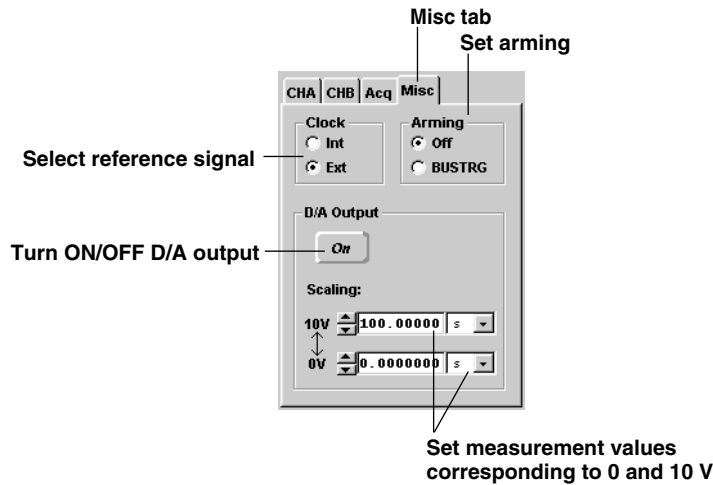

Selecting the Reference Signal

To use the external input signal as a reference signal, select [Ext] under the [Clock] option buttons. For the procedures to input the external reference signal, see page 2-4.

Setting the Arming

When the acquisition mode is [One Shot] and you wish to start the measurement operation when the bus trigger signal (BUSTRG1, 2) of the measuring station is detected, select [BUSTRG] under the [Arming] option buttons. For details on setting the bus trigger signal, see section 4.6, “Setting the Trigger Source/Time Base Source/Arming” in the WE7000 User’s Manual.

Turning the D/A Output ON/OFF

To convert the measured values to analog signals with voltages between 0 to 10 V and output them, click the [On] button under [D/A Output]. Clicking the button again turns OFF the D/A output. The output values are set by entering the measured values corresponding to 0 V and 10 V. The selectable range of the output values is 0 to 109. For the procedures to connect the D/A output terminal, see page 2-4.

When outputting the frequency measurement values

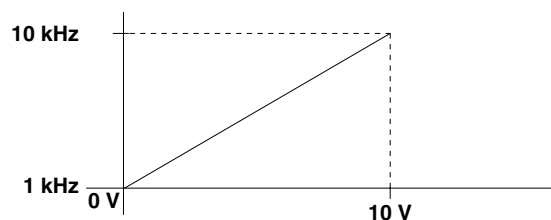

Controlling the Timing of the Start of the Measurement (Arming)

To start the measurement using the arming signal, set the arming in the dialog box that appears by clicking [Trigger] on the menu bar. For details on setting the arming signal, see section 4.6, “Setting the Trigger Source/Time Base Source/Arming” in the WE7000 User’s Manual.

4.1 Troubleshooting

- If servicing is necessary, or if the instrument is not operating correctly after performing the following corrective actions, contact your nearest YOKOGAWA dealer.
- To verify that the module is operating correctly, perform the self test as described on the next page.

Problem	Probable Cause/Corrective Action	Reference
Module does not operate.	Check to see that the module is installed correctly into the station. Also, install the module into another slot, and check whether it will operate there. If it operates in the other slot, the measurement station is likely to have malfunctioned. If the module is installed correctly and does not operate, the fuse might have melted, the connector might be bad or the IC may have malfunctioned. In any case, contact your nearest YOKOGAWA dealer to have it repaired.	2-1, 3-1, *
Measured values are not correct.	Check whether the ambient temperature and humidity are within the allowed ranges. If you did not allow a warm-up time of 30 minutes, try measuring again after the warm-up time has passed. If the frequency of the signal being measured is 35 Hz or less, set the input coupling to DC, and set the appropriate trigger level with the manual trigger. If there is a lot of noise in the input signal, use an attenuator to lower the input signal level.	5-5 3-1 to 3-8
Trigger is not generated.	The trigger level may not be set properly. Set the trigger to auto or set an appropriate value for the manual trigger. If using the bus trigger signal for starting the measurement (arming), verify that the settings are correct in the trigger source/time base/arming setting dialog box of the WE7000 Control Software that appears by selecting [Station] - [Trigger Setting] in the station window.	3-1 to 3-8 *
The waveform monitor is not displayed.	Check that the [Waveform monitor ON/OFF] button, that is located to the right of the [Start] button on the operation panel, is turned ON.	3-9

* See the WE7000 User's Manual (IM 707001-01E).

4.2 Self Test

If you believe that the module is not operating correctly, perform the self test according to the following steps.

Executing Self Test

1. Select [Self Test] from the [System] menu of the WE7000 Control Software.



2. In the [Self Test] dialog box that appears, select the station name and enter the slot number corresponding to the module, and click the [Execute] button.

“Executing...” is displayed in the [Result] display box.

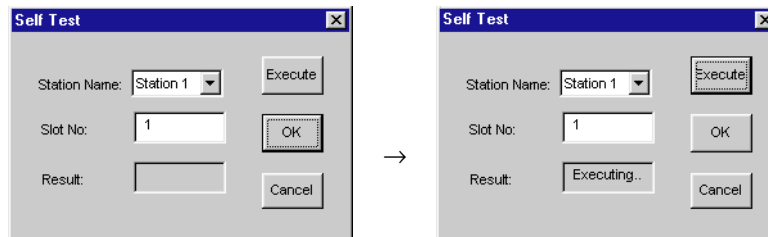

Verifying Test Results

If a value other than “0” is displayed in the “Result” display box of the “Self Test” dialog box, the module is probably malfunctioning. Please contact your nearest YOKOGAWA dealer.

4.3 Maintenance

Maintenance of Parts

There are no parts in this module that require periodic replacement.

Calibration

We recommend that you calibrate the measurement module once a year to assure its measurement accuracy. Please contact your nearest YOKOGAWA dealer.

5.1 Input Section Specifications

Number of Input Channels

2 (A, B)

Input Format

Non-isolated unbalanced

Connector Type

BNC

Input Impedance

1 M Ω /40 pF (Typical value^{*1})

Input Coupling

DC, AC

Low Frequency –3 dB Point during AC Coupling

35 Hz (Typical value^{*1})

Attenuator

 $\times 1$, $\times 10$

Trigger Level

When the attenuator is set to $\times 1$: –5 V to +5 V (resolution: 20 mV)When the attenuator is set to $\times 10$: –40 V to +40 V (resolution: 200 mV)Setting accuracy^{*2}: $\pm 10\% \pm 30$ mV of the set value (When the attenuator is set to $\times 1$)

Trigger Slope

Rise, Fall

Auto Trigger

Automatically set to the center value of the input amplitude

Operation frequency range: Sine wave 50 Hz to 120 MHz (sensitivity: 250 mV rms)

Operation voltage range: ± 5 V (When the attenuator is set to $\times 1$)

Input Sensitivity^{*2}

50 mV rms: DC < input frequency \leq 60 MHz100 mV rms: 60 MHz < input frequency \leq 120 MHz

Maximum Input Voltage

40 V (DC + AC_{peak}): DC \leq input frequency < 4 MHz140/f [MHz] + 5 [V (DC + AC_{peak})] 4 MHz \leq input frequency < 120 MHz

(Overvoltage Category: CAT I and II)

Channel B Gate

Gate signal used during frequency A and totalize count measurements

Input range: Gate setting pulse width is 100 ns to 100 s

(The number of input cycles of channel A within the gate time does not exceed 2^{32} counts.)

Gate time of channel B > One period of the input signal of channel A

Minimum Input Pulse Width^{*2}

10 ns (except when using 1/2 prescaler)

*1 Typical value represents a typical or average value. It is not strictly guaranteed.

*2 Value or allowed value obtained during standard operating conditions.

5.2 Specifications of Individual Measurement Functions

Frequency A

Measurement range

1 Hz to 120 MHz (when using 1/2 prescaler), 1 mHz to 60 MHz

Gate time^{*1}

When using prescaler: 10 ms, 100 ms, 1 s, 10 s

When not using prescaler: 10 ms, 100 ms, 1 s, 10 s, CH B gate (channel B pulse width)

Resolution

$$\frac{\pm 10 \text{ ns} \pm \sqrt{2} \times \text{Trigger error}^{*3}}{\text{Gate time}} \times \text{Measurement frequency [Hz]}$$

Accuracy^{*2}

Resolution $\pm(\text{Time base aging} \times \text{measurement frequency})$ [Hz]

Period A

Measurement range

20 ns to 999.999999 s

Multiplier

1, 10, 100, 1000

Resolution

$$\frac{\pm 10 \text{ ns} \pm \sqrt{2} \times \text{Trigger error}^{*3}}{10^N} \text{ [s]} \left(\begin{array}{l} 10^N \text{ is the multiplier} \\ N = 0, 1, 2, 3 \end{array} \right)$$

Accuracy^{*2}

Resolution $\pm(\text{Time base aging} \times \text{measurement frequency})$ [s]

Time Interval A → B

Measurement range

60 ns to 999.999999 s

Input frequency range

1 mHz to 50 MHz (for input channels A and B)

Multiplier

1, 10, 100, 1000

Measurement suspension time

200 ns (when multiplier = 10, 100, 1000)

Resolution

$$\frac{\pm 10 \text{ ns} \pm \text{Channel A input trigger error}^{*3} \pm \text{Channel B input trigger error}^{*3}}{\sqrt{10^N}} \text{ [s]} \left(\begin{array}{l} 10^N \text{ is the multiplier} \\ N = 0, 1, 2, 3 \end{array} \right)$$

Accuracy^{*2}

Resolution $\pm(\text{Time base aging} \times \text{measurement time}) \pm \text{trigger level timing error}^{*4} \pm 10 \text{ ns}$
error between channels^{*5}

Pulse Width A

Measurement range

20 ns to 999.999999 s

Multiplier

1, 10, 100, 1000

Resolution

$$\frac{\pm 10 \text{ ns} \pm \text{Rising edge trigger error}^{*3} \pm \text{Falling edge trigger error}^{*3}}{\sqrt{10^N}} \text{ [s]} \left(\begin{array}{l} 10^N \text{ is the multiplier} \\ N = 0, 1, 2, 3 \end{array} \right)$$

Accuracy^{*2}

Resolution $\pm(\text{Time base aging} \times \text{measurement time}) \pm \text{trigger level timing error}^{*4}$

Duty Cycle A**Measurement range**

0.00000001 to 0.99999999

Input range

20 ns to 999.999999 s

Multiplier

1, 10, 100, 1000

Displayed units

Value is displayed as a ratio (50% is displayed as 0.5)

Resolution $\pm((\text{Pulse width} + |\text{Pulse width resolution}|)/(\text{period} - |\text{period resolution}|) - \text{measured duty value})$ **Accuracy*2** $\pm((\text{Pulse width} + |\text{Pulse width accuracy}|)/(\text{period} - |\text{period accuracy}|) - \text{measured duty value})$ **Frequency Ratio A/B****Measurement range**

0.001 to 999999999

(When multiplier = 1, 0 is displayed when frequency A < B)

Input range

1 mHz to 60 MHz

Multiplier

1, 10, 100, 1000

Resolution
$$\frac{\pm \text{Channel A input 1 count} \pm \sqrt{2} \times \text{Channel B input trigger error}^{*3}}{10^N} \text{ [s]} \quad \left(\begin{array}{l} 10^N \text{ is the multiplier} \\ N = 0, 1, 2, 3 \end{array} \right)$$
Accuracy*2

Same as the resolution

Totalized Count A**Input frequency range**

1 mHz to 50 MHz

Counting capacity0 to 2⁵² (except 0 to 109 on the WE7000 Control Software)**Counting error**

±1 count during channel B gate measurement

Counting control

Manual start or channel B gate (pulse width)

*1 When one period of the input frequency is greater than or equal to the set gate time, the gate time is the time over one period of the input signal.

*2 Value obtained under standard operating conditions. Values outside the measurement range are not guaranteed.

*3 Trigger error = $\sqrt{X^2 + E_n^2} / \text{SR}$ [s]

X: Counter input section noise = 600 [μV rms], E_n: Signal noise [V rms] within the input amp bandwidth (120 MHz),

SR: Slew rate of the input signal at the trigger level [V/s]

*4 Trigger level timing error = $\pm(20 \text{ mV/SR (START)} - 20 \text{ mV/SR (STOP)}) \pm(\text{Trigger level setting accuracy/SR (START)}) \pm(\text{Trigger level setting accuracy/SR (STOP)})$ [s]

SR (START): Slew rate of the input signal of channel A at the trigger level [V/s] (Time interval measurement)

Slew rate of the rising/falling slopes [V/s] (pulse width measurement)

SR (STOP): Slew rate of the input signal of channel B at the trigger level [V/s] (Time interval measurement)

Slew rate of the rising/falling slopes [V/s] (pulse width measurement)

*5 10 ns error between channels: Error due to the difference in the internal delay of channels A and B.

5.3 External Input/Output Specifications

D/A Output

Output voltage range

0 to + 10 V (under high impedance load)

Linear conversion, full scale 15 bit D/A

Range selectable range

Set the maximum and minimum values of the range to perform D/A conversion

Setting range: 0 to 2^{52} (except 0 to 10^9 on the WE7000 Control Software)

Maximum output current

± 2 mA

Output format

Non-isolated unbalanced

Connector type

BNC

Reference Time Specifications

Internal reference frequency

10 MHz

Frequency stability^{*1}

Aging rate: $\pm 1.5 \times 10^{-6}$ /yr

Temperature characteristics: $\pm 3 \times 10^{-6}$ (5°C to 40°C)

Reference output

Connector type: BNC

Output coupling: AC

Output impedance: 50 Ω (Typical value^{*2})

Output frequency: 10 MHz (Typical value^{*2})

Output level: 1 V p-p or more (under 50 Ω load)

External reference input^{*1}

Connector type: BNC

Input coupling: AC

Input impedance: 1 k Ω or more

Input frequency range: 10 MHz ± 10 Hz

Input level: 1 V p-p or more

Maximum input voltage: ± 10 V (Overvoltage Category: CAT I and II)

Alarm Output

Monitors the upper and lower limits of the measured values during continuous measurement and outputs trigger signals to the WE Bus (BUSTRG1/BUSTG2).

*1 Value or allowed value obtained during standard operating conditions.

*2 Typical value represents a typical or average value. It is not strictly guaranteed.

5.4 Default Values (Factory Default Settings)

CHA settings

Repeat (measuring continuously): On
Function (measurement parameters): Frequency A
Coupling (input coupling): AC
Attenuator (Attenuator): x1
Slope (trigger slope): Rise
Prescale (prescaler): 1/1
Auto (auto trigger): On
Gate time (gate time): 10 ms

Acq setting

Acq Mode (aquisition mode): One Shot

Misc setting

Clock (reference signal): Int
Arming (arming): Off
D/A Output (D/A output): On
Scaling 10V (Measured value corresponding to 10 V during D/A output): 120.00000 MHz
Scaling 0V (Measured value corresponding to 0 V during D/A output): 0 μ Hz

5.5 General Specifications

Safety Standards

Complies with CSA C22.2 No.1010.1 and EN61010-1, conforms to JIS C1010-1.

- Overvoltage category CAT I and II¹
- Pollution degree 1 and 2²

EMC Standards

Emission

Complying standard

EN55011 Group 1 Class A

This product is a Class A (for industrial environment) product. Operation of this product in a residential area may cause radio interference in which case the user is required to correct the interference.

Cable requirement

Double shielded coaxial cables (3D-2W BNC cable)

Immunity

Complying standard

EN50082-2

Testing condition

Frequency A measurement mode. Connect to CH A from Reference OUTPUT with 3 m double shielded coaxial cable. Connect 3m double shielded coaxial cable to other input with open terminated.

Standard Operating Conditions

Temperature: 23 ±2°C, humidity: 50 ±10% RH,

Power voltage/frequency error: within 1% of rating, after the warmup time has passed

Warm-up Time

At least 30 minutes

Operating Conditions

Same as those of the measuring station

Storage Conditions

Temperature: -20 to 60°C

Humidity: 20 to 80% RH

Power Consumption

6 VA (Typical value at 100 V/50 Hz³)

Weight

Approx. 0.7 kg

External Dimensions

Approx. 33(W) × 243(H) × 232(D) mm (projections excluded)

Number of Used Slots

1

Standard Accessories

User's Manual (1)

Optional accessories

700976	50 Ω terminator
366921	Adapter (BNC plug - banana terminal jack)
366923	Connection adapter (T-shaped BNC)
366924	BNC cable (1 m)
366925	BNC cable (2 m)
366926	BNC alligator clip cable (1 m)

- ^{*1} Overvoltage Categories define transient overvoltage levels, including impulse withstand voltage levels.
Overvoltage Category I: Applies to equipment supplied with electricity from a circuit containing an overvoltage control device.
Overvoltage Category II: Applies to equipment supplied with electricity from fixed installations like a distribution board.
- ^{*2} Pollution Degree: Applies to the degree of adhesion of a solid, liquid, or gas which deteriorates withstand voltage or surface resistivity.
Pollution Degree 1: Applies to closed atmospheres (with no, or only dry, non-conductive pollution).
Pollution Degree 2: Applies to normal indoor atmospheres (with only non-conductive pollution).
- ^{*3} Typical value represents a typical or average value. It is not strictly guaranteed.

5.6 Dimensional Drawings

Unit: mm

100 MHz Universal Counter Module (WE7141)

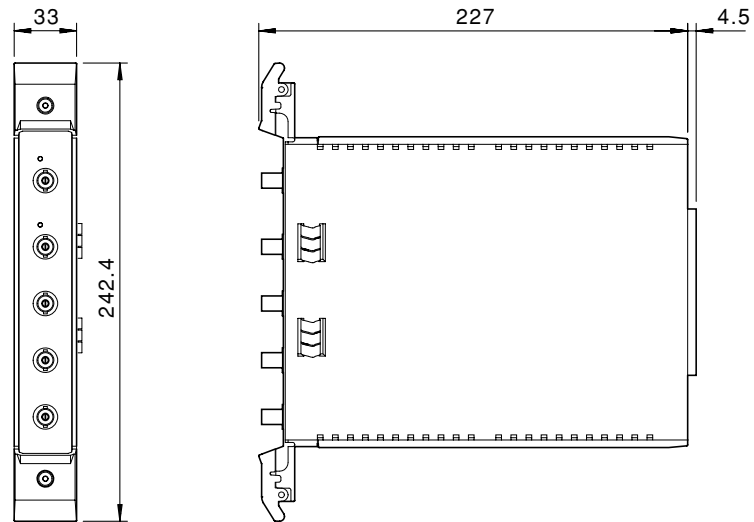

If not specified, the tolerance is $\pm 3\%$. However, in cases of less than 10 mm, the tolerance is ± 0.3 mm.

Index

A

AC 1-5
 Accuracy, measurement 1-9
 Acq Mode 3-9
 Acquisition mode, selecting 1-7, 3-9
 Alarm 3-10
 Alarm output 1-7
 Arming 1-7, 3-11
 Attenuator 1-5
 Auto trigger 1-5

C

CH 1-13
 Clock 3-11

D

D/A OUT 1-13
 D/A Output 1-8, 2-4, 3-11
 D/A output, turning ON/OFF 3-11
 DC 1-5
 Difference 3-9
 Displayed value, holding 1-8
 Duty Cycle A 1-3, 3-6
 Duty cycle measurement 3-6

E

Ext 3-11
 Ext Gate 3-8
 External reference signal input 1-8, 2-4
 External reference signal input terminal 1-13

F

Fall 1-7, 3-10
 Free Run 1-7, 3-9
 Frequency A 1-3, 3-1
 Frequency measurement 3-1
 Frequency ratio A/B 1-3
 Frequency ratio measurement 3-7

G

Gate 1-6
 Gate, selecting ON/OFF 3-8
 Gate Time 3-2
 Gate time and resolution 1-10

I

In 1-7, 3-10
 INPUT 1-13, 2-3
 Input connection 2-3
 Input coupling 1-5
 Input terminal 1-13

M

Manual trigger 1-5
 Measured data, saving 1-7, 3-10
 Measurement accuracy 1-9
 Measurement principle 1-1
 Mode 3-10
 MODEL 2
 Module, installation of 2-1
 Monitor panel 1-8
 Multiplier 1-6, 1-10

N

NO 2

O

One Shot 1-7
 Out 1-7, 3-10

P

Package 2
 Period A 1-3, 3-3
 Period measurement 3-3
 Prescaler 1-5
 Pulse Width A 1-3, 3-5
 Pulse width measurement 3-5

R

Ratio A/B 3-7
 REFERENCE 1-13
 Reference signal output 2-4
 Reference signal output terminal 1-13
 Reference signal, selecting 3-11
 Rise 1-7, 3-10

S

Sampling interval, setting 3-9
 Scale conversion 1-7
 Scale conversion, setting 3-9
 Self test 4-2
 Start timing of measurement, controlling 1-7
 Start timing of measurement, setting 3-11

T

T Interval A-B 1-3, 3-4
 Time base error 1-11
 Time Interval A Δ B 1-3
 Time interval measurement 3-4
 Totalize A 1-4, 3-8
 Totalize count A 1-4
 Trigger indication LED 1-13
 Trigger level 1-5
 Trigger level timing error 1-11
 Trigger setting 3-11
 Trigger slope 1-5
 Troubleshooting 4-1